

Aerodynamic Optimization of a Savonius Wind Turbine Using Multiple Configurations of Fixed Deflectors

Basile Blanchard – Kasetsart University (Thailand) / ECAM LaSalle Lyon (France), Pr. Weerachai – Kasetsart University (Thailand), Pr. Jay-Tawee – Kasetsart University (Thailand)

Introduction

Subject:

- **Domain** : Urban wind energy requires turbines able to operate in low and turbulent winds.
- **Method** : Savonius Vertical Axis Wind Turbines (VAWT) are robust and self-starting but suffer from low aerodynamic efficiency.

Problem:

The returning blade generates negative torque which reduces overall power output.

Objectives

Investigate how passive aerodynamic deflectors can improve Savonius turbine performance using CFD simulations.

Configurations tested:

1. Classic Savonius (baseline)
2. Six flat deflectors
3. Two curved arc deflectors
4. Three Venturi-type convergent deflectors

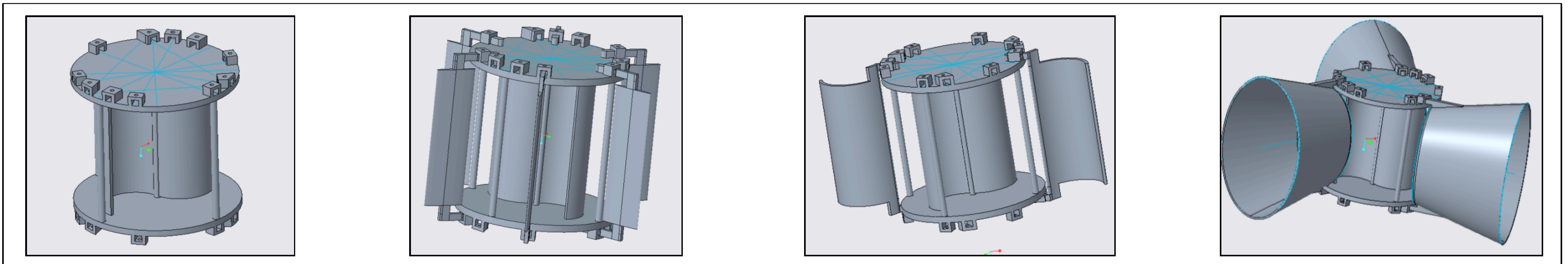

Methods

1. Methodology:

- 3D CAD models created using PTC Creo
- Aerodynamic simulations performed in ANSYS Fluent

2. Simulation approach:

- Computational Fluid Dynamics (CFD)
- Rotating reference frame for turbine motion
- Urban wind speed conditions

3. Performance indicators:

- Aerodynamic torque
- Moment coefficient (Cm)
- Flow pathlines and pressure distribution

4. Purpose:

Quantify aerodynamic impact of each deflector design under identical conditions.

Results

Torque comparison: Venturi > Flat > Arc > Classic

Findings:

- **Classic turbine** shows strong torque oscillations
- **Arc deflectors** produce smoother and stronger torque
- **Flat deflectors** redirect flow but create turbulence
- **Venturi deflectors** accelerate airflow and generate the highest torque

Flow visualization shows:

- Reduced turbulence with curved guides
- Flow acceleration in Venturi geometry
- Better shielding of the returning blade

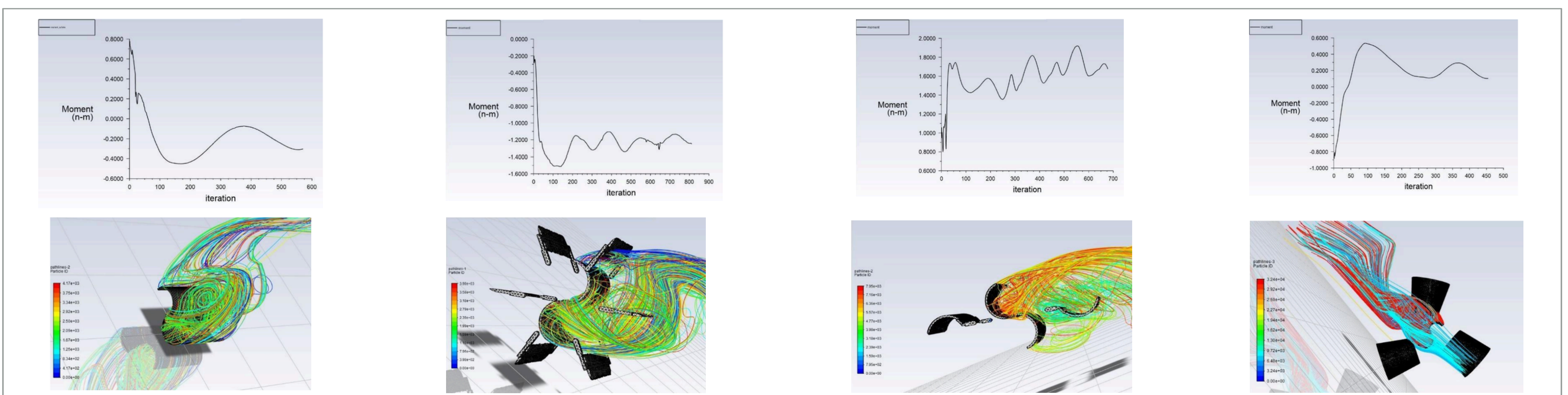

CONCLUSION

The results of this numerical investigation clearly demonstrate that the integration of passive aerodynamic deflectors can significantly enhance the performance of a Savonius vertical axis wind turbine. By redirecting the incoming airflow toward the advancing blade while simultaneously shielding the returning blade, these structures effectively reduce the negative torque that typically limits the efficiency of conventional Savonius rotors.

Among the configurations analyzed in this study, the Venturi-type deflector design provided the most substantial aerodynamic improvement. The convergent geometry accelerates the incoming airflow before it reaches the rotor, increasing the local dynamic pressure and consequently the driving torque applied to the advancing blade. This passive flow acceleration mechanism allows the turbine to extract more energy from low-speed wind conditions, which are commonly encountered in urban environments. These findings highlight the strong potential of passive flow-control strategies as a simple, cost-effective approach to improving the aerodynamic efficiency of drag-based vertical axis wind turbines without significantly increasing mechanical complexity.

Future Work: Future research will focus on experimentally validating the numerical results through prototype fabrication and wind tunnel testing. These experiments will allow comparison between simulated and real turbine performance under controlled wind conditions. In addition, integrating a smart orientation system using wind sensors could enable the turbine and its deflectors to automatically align with the prevailing wind direction, improving overall energy capture in variable urban wind environments.

Keywords: Savonius Turbine • Vertical Axis Wind Turbine • CFD • Deflectors • Urban Wind Energy